

-SQA - SCOTTISH QUALIFICATIONS AUTHORITY
HIGHER NATIONAL UNIT SPECIFICATION
GENERAL INFORMATION

-Unit Number- 2660048

-Unit title- Electrical Supply and Distribution Systems

-Superclass category- XK

-Date of publication- April 1998

-Originating centre for unit- Cleveland Open Learning Unit

-DESCRIPTION-

GENERAL COMPETENCE FOR UNIT:

Analysing electrical supply systems, co-ordinating the protection and applying tariffs for such systems.

OUTCOMES:

1. interpret an electrical distribution system;
2. analyse an electrical supply system represented by passive electrical components;
3. analyse fault conditions in an electrical supply system;
4. interpret load flow between two power systems;
5. determine the operating characteristics of three-phase synchronous generators connected to infinite bus bars;
6. relate the operation of three-phase transformers to their suitability for parallel operation;
7. describe methods of a.c. circuit breaking;

8. describe the operation of protection systems;
9. relate the factors affecting the economics of electrical supply systems to the tariffs imposed.

CREDIT VALUE: 2 HN Credits

ACCESS STATEMENT:

Access to this unit is at the discretion of the centre. It would, however, be beneficial if the candidate had a background in electrical supply systems. This may be evidenced by possession of the Higher National Unit Circuit, Fields and Networks or a similar qualification.

Additional copies of this unit can be obtained from:

The Administrative Services Unit, SQA, Hanover House, 24 Douglas Street, Glasgow G2 7NQ, (Tel: 0141-242 2168).

At the time of publication, the cost is £1.50 (minimum order £5).

HIGHER NATIONAL UNIT SPECIFICATIONS

STATEMENT OF STANDARDS

Unit Number: 2660048

Unit Title: Electrical Supply and Distribution Systems

Acceptable performance in this unit will be the satisfactory achievement of the standards set out in this part of the specification. All sections of the statement of standards are mandatory and cannot be altered without reference to SQA.

OUTCOME 1

INTERPRET AN ELECTRICAL DISTRIBUTION SYSTEM

PERFORMANCE CRITERIA

- (a) A single line schematic diagram of an electrical supply system is correctly interpreted.
- (b) Functions of isolators, contactors, fuses and circuit breakers are clearly explained and compared.
- (c) Radial and ring main distribution systems and their applications are clearly described and compared.
- (d) For a given fault in a supply system, the circuit breakers that should open and the section of the system which should be disconnected are correctly identified.

RANGE STATEMENT

Block diagram elements: generators and transformers; 400/275/132 kV transmission lines; grid transformer/switching station; 33 kV distribution network; primary substation (33/11 kV); 11 kV distribution network (including rural lines); 415 V distribution network; load points on high and low voltage networks (including factory and domestic installations).

EVIDENCE REQUIREMENTS

Diagrammatic, written or written and oral evidence of the candidate's ability to explain and compare the items required by the PCs (a), (b), (c) and (d).

OUTCOME 2

ANALYSE AN ELECTRICAL SUPPLY SYSTEM REPRESENTED BY PASSIVE ELECTRICAL COMPONENTS

PERFORMANCE CRITERIA

- (a) The full and appropriate equivalent circuits for the component parts of a system are clearly drawn.
- (b) A representative phase-equivalent circuit of a supply system is clearly drawn.
- (c) The load voltage levels at different points in a supply system are clearly determined.

RANGE STATEMENT

Electrical Supply System: one generator and two loads maximum.

Component parts: generators; transformers; lines and loads.

Component parameters: R ; L and C .

Representative phase-equivalent circuit: inductance only.

EVIDENCE REQUIREMENTS

Diagrammatic, written or written and oral evidence of the candidate's ability to represent and explain the items required by PCs (a) and (b).

Written evidence of the candidate's ability to predict load voltages, as described in PCs (b) and (c).

OUTCOME 3

ANALYSE FAULT CONDITIONS IN AN ELECTRICAL SUPPLY SYSTEM

PERFORMANCE CRITERIA

- (a) Symmetrical fault levels at different points in a supply system and the inductor values required to reduce these fault levels to specified values are accurately calculated.
- (b) Switchgear and fuse ratings are appropriate for the predicted fault level.
- (c) The different types of asymmetrical faults are correctly listed.

RANGE STATEMENT

Electrical Supply System: four generators feeding sectionalised busbar; two generators and national grid feeding sectionalised busbar.

Asymmetric faults: line-to-earth; double line-to-earth; line-to-line; broken conductor.

EVIDENCE REQUIREMENTS

Written evidence of the candidate's ability to calculate fault levels, as described in PC (a) to cover the two system configurations given in the range.

Written or oral evidence of the candidate's ability to justify ratings as described in PC (b).

Written or oral evidence of the candidate's ability to list the range as described in PC (c).

OUTCOME 4

INTERPRET LOAD FLOW BETWEEN TWO POWER SYSTEMS

PERFORMANCE CRITERIA

- (a) A receiving-end line chart for a short transmission line is correctly developed using per-unit and ohmic values.
- (b) The control of real and reactive power by transmission angle and sending-end voltage is clearly demonstrated.

- (c) The control of sending-end voltage by the generation of reactive power at the receiving end is clearly demonstrated.

RANGE STATEMENT

The range for this item is fully expressed within the performance criteria.

EVIDENCE REQUIREMENTS

Diagrammatic and written or written and oral evidence of the candidate's ability to produce and use the chart required by PC (a).

Written evidence of the candidate's ability to produce calculations to demonstrate the principles described in PCs (b) and (c).

OUTCOME 5

**DETERMINE THE OPERATING CHARACTERISTICS OF
THREE-PHASE SYNCHRONOUS GENERATORS CONNECTED
TO INFINITE BUS BARS**

PERFORMANCE CRITERIA

- (a) A capability chart of the generator is correctly constructed.
- (b) The performance limitations of a generator are clearly demonstrated from its capability chart.

RANGE STATEMENT

Performance limitations: stator heating limit (MVA limit); rotor heating limit (excitation limit); prime mover limit (MW limit); stability limit (theoretical and practical).

EVIDENCE REQUIREMENTS

Diagrammatic and written evidence of the candidate's ability to produce and use the chart described by PCs (a) and (b).

OUTCOME 6

RELATE THE OPERATION OF THREE-PHASE TRANSFORMERS TO THEIR SUITABILITY FOR PARALLEL OPERATION

PERFORMANCE CRITERIA

- (a) The phase relationship between primary and secondary voltages of a three-phase transformer is clearly determined.
- (b) The essential and desirable conditions for the parallel operation of two three-phase transformers are clearly stipulated.
- (c) The load on each transformer is accurately calculated.
- (d) Voltage control by tap-changing is clearly described.

RANGE STATEMENT

Phase relationship: 0° ; 180° ; -30° ; $+30^\circ$.

Essential conditions: same polarity, phase sequence and grouping.

Desirable conditions: same voltage ratio and per-unit impedance.

EVIDENCE REQUIREMENTS

PC (a): written or oral and diagrammatic evidence of the candidate's understanding of how a transformer's winding connection determines the primary to secondary voltage phase relationship.

Written and diagrammatic evidence of the candidate's knowledge and understanding of the conditions described in PC (b).

Written evidence of the candidate's ability to calculate transformer loads as described in PC (c).

Written or oral evidence of the candidate's knowledge and understanding of voltage control as described in PC (d).

OUTCOME 7

DESCRIBE METHODS OF A.C. CIRCUIT BREAKING

PERFORMANCE CRITERIA

- (a) The principle of arc suppression, control and interruption is clearly described with reference to h.v. fuses and circuit breakers.
- (b) Waveforms of currents and voltages , from the onset of a three-phase symmetrical fault to final clearance of the fault, are clearly sketched.
- (c) Recovery transient parameters are accurately calculated for a lumped LC model of a circuit breaker.

RANGE STATEMENT

h.v. fuses: HRC liquid fuse; HRC explosion fuse.

Circuit breakers: oil; air-blast; vacuum; sulphur hexafluoride.

Waveforms: system voltage; system current; voltage across circuit breaker contacts; recovery voltage transient .

Recovery parameters: frequency of voltage transient; maximum voltage; average rate of rise of recovery voltage.

EVIDENCE REQUIREMENTS

PC (a): Written and diagrammatic evidence of the candidate's ability to describe the items required over the given range.

PC (b): Diagrammatic evidence of the candidate's ability to sketch typical waveforms produced by a three-phase symmetrical faults.

PC (c): Written evidence of the candidate's ability to calculate specified transient parameters.

OUTCOME 8

DESCRIBE THE OPERATION OF PROTECTION SYSTEMS

PERFORMANCE CRITERIA

- (a) Elements used in over-current protection systems are clearly described.
- (b) The operation of an IDMT relay used for over-current protection is clearly described.
- (c) The TMS and the PSM settings for an IDTM relay are accurately calculated to give the required discrimination in radial and ring circuits.
- (d) A unit protection system is clearly described.
- (e) Over-voltage protection methods are clearly described.

RANGE STATEMENT

Elements: current transformers; voltage transformers; summing transformers.
Over-voltage methods: overhead earth wire; rod-gap; surge diverters.

EVIDENCE REQUIREMENTS

Diagrammatic, written or written and oral evidence of the candidate's ability to describe the items required by the PCs (a), (b), (d) and (e).

Written evidence of the candidate's ability to calculate the settings as described in PC(c).

OUTCOME 9

RELATE THE FACTORS AFFECTING THE ECONOMICS OF ELECTRICAL SUPPLY SYSTEMS TO THE TARIFFS IMPOSED

PERFORMANCE CRITERIA

- (a) The factors used in determining the economics of the supply system are clearly explained.
- (b) Schemes for the matching of supply to load demand are clearly explained.

- (c) A two-part tariff (fixed and running charges) is correctly interpreted to compute a monthly bill.

RANGE STATEMENT

Factors: capital costs; running costs; load factor; diversity factor; power factor; maximum demand; interest; depreciation.

Schemes: spinning reserve; hot standby; pumped storage.

EVIDENCE REQUIREMENTS

Written or written and oral evidence of the candidate's ability to describe the items required by the PCs (a) and (b) across their respective ranges.

Written evidence of the candidate's ability to calculate bills as described in PC (c).

MERIT To gain a pass in this unit, a candidate must meet the standards set out in the outcomes, performance criteria, range statements and evidence requirements.

To achieve a merit in this unit, a candidate must demonstrate a superior or more sophisticated level of performance. In this unit this might be shown in the following ways:

- (a) by the transfer of a competence gained in one situation to a related but unfamiliar situation;
- (b) by integrating the knowledge of two or more outcomes to solve problems that are more complex than would be necessary to demonstrate competence in a single outcome;
- (c) by the demonstration of a critical awareness of the subject matter in relation to current practice in electrical supply and distribution;
- (d) by exercising sound engineering judgment in the solution to a problem.

ASSESSMENT

In order to achieve this unit, candidates are required to present sufficient evidence that they have met all the performance criteria for each outcome within the range specified. Details of these requirements are given for each outcome. The assessment model and an integrative approach to assessment is encouraged. (See references at the end of support notes).

Accurate records should be made of the assessment instruments used showing how evidence is generated for each outcome and giving marking schemes and/or checklists, etc. Records of candidates' achievements should be kept. These records will be available for external verifications.

SPECIAL NEEDS

Proposals to modify, range statements or agreed assessment arrangements should be discussed in the first place with the external verifier.

© Copyright SQA 1998

Please note that this publication may be reproduced in whole or in part for educational purposes provided that:

- (i) no profit is derived from the reproduction
- (ii) if reproduced in part, the source is acknowledged

HIGHER NATIONAL UNIT SPECIFICATION

SUPPORT NOTES

Unit number: 2660048

Unit title : Electrical Supply and Distribution Systems

SUPPORT NOTES:

This part of the unit specification is offered as guidance. None of the sections of the support notes is mandatory.

NATIONAL DESIGN LENGTH:

SQA allocates a notional design length to a unit on the basis of time estimated for achievement of the stated standards by a candidate whose starting point is described by the access statement. The notional design length for this unit is 80 hours. The use of notional design length for programme design and time tabling is advisory only.

PURPOSE

The unit provides candidates with a background in and underpinning knowledge of the engineering and economic aspects of supply, distribution and protection of electricity.

CONTEXT/CONTENT

The following information gives further clarification regarding the context in which the outcomes and performance criteria are to be achieved:

Outcome 1:

National Electrical Supply Systems - overview.

Transmission and distribution - voltages on the UK supply network.

Functions of isolators, contactors, fuses and circuit breakers.

Radial, parallel and ring main distribution systems.

System faults and disconnection of supply on radial and ring systems. Application of discrimination. Need for inverse-time relays and directional overcurrent relays.

BS3939 gives device symbols and BS5070 gives examples of drawing practice.

Candidates may find it helpful to draw the distribution system for their home or work place to illustrate radial and ring systems.

Outcome 2:

Equivalent circuits:

generators, transformers, lines, loads.
Circuit parameters R, L, C and G.

Representative Phase Equivalent Circuits:

phase equivalent of generators, transformers, lines, loads.

Load voltage levels in a supply system:

electricity supply regulations;
volt-drop calculations on radial, parallel and ring feeders (equivalent circuits using reactance only).

Equivalent circuits:

A generator can be represented by a generated emf in series with an impedance consisting of the winding resistance and the synchronous reactance.

Lines can be represented by lumped R, L, C and G. A short line (<80 km) can be modelled by R and L only, a medium line (<250 km) by R, L and C but a long line must be modelled by all four parameters.

A transformer equivalent circuit consist of an ideal transformer with series winding resistance and leakage inductance in both primary and secondary windings. These parameters can be reflected from primary to secondary or vice versa if desired. The primary winding will also be shunted by a resistor representing core losses and an inductor carrying the magnetising current.

Loads (industrial) will mainly consist of induction motors, which can be modelled by a variable resistor whose value varies with the mechanical output power. In series with this resistor will be the stator resistance and inductance and also the rotor resistance and inductance, referred to the stator. Finally, the input will be shunted by a resistor representing core losses and an inductor that carries the magnetising current.

Phase equivalent circuits:

assumptions: resistance, magnetising branch of transformers, shunt capacitance of lines are all ignored.

Outcome 3:

Determination of Fault Levels:

definition of fault level, method of determining fault level, symmetrical three-phase short circuit.

Reducing fault level to specified value:

calculation of inductor value to limit fault level to acceptable value. Use of sectionalised busbars.

Relating switchgear and rating to fault level:

selection of rated current, rated voltage, rated short-circuit breaking current.

Asymmetric faults:

identification of line-to-earth, double-line-to-earth, line-to-line, broken conductor.

Problems involving two generators and the national grid (11 kV sectionalised busbar fed from two generators and the 132 kV grid, for example) will involve delta-to-star conversion:

$$Z_1 = (Z_{12}Z_{13}) / (Z_{12} + Z_{23} + Z_{13})$$

$$Z_2 = (Z_{12}Z_{23}) / (Z_{12} + Z_{23} + Z_{13})$$

$$Z_3 = (Z_{23}Z_{13}) / (Z_{12} + Z_{23} + Z_{13})$$

A network analyser could be used to support this outcome.

Outcome 4:

Receiving-end line chart for a short transmission line.

Control of real and reactive power by transmission angle and sending-end voltage.

Control of sending-end voltage by generation of reactive power at receiving end.

Outcome 5:

Concept of the infinite bus bar.

Equivalent circuit of the synchronous machine (E , R and XS) connected to a busbar load of voltage V and at some power factor .

Phasor diagram of the synchronous machine.

Load diagram of the synchronous machine, obtained by multiplying phasor currents by busbar voltage, with P on the real axis and Q on the imaginary axis. P, Q, I, E , and (load angle) identified from it.

Capability chart obtained by adding operational limits to the load diagram.

Outcome 6:

Phasor groups:

waveforms and or phasor diagrams relating line and phase phasors;
phase displacement, group numbers and clock numbers;
three-phase connections, phasor diagrams and name plate symbols.

Load sharing:

determination of load sharing in two transformers in parallel supplying a common load (given the winding resistance and leakage reactance of each ($R + jX$) but neglecting shunt impedance).

Condition for parallel operation:

relevance of polarity, phase sequence and phase grouping voltage ratio and unit impedance.

Voltage control by tap changing:

supply point voltage control by variation of transformer terminal voltage;
transmission line connecting to generators via tap-changer machines.

PC (a) BS171 part 4 defines transformer phase relationships. The range is given by the connections:

STAR -STAR; STAR-DELTA; DELTA-STAR; DELTA-DELTA.

PC (c) Assessment requires only examples of transformers with equal voltage ratios.

Outcome 7:

Circuit breaker equivalent circuit consisting of series inductor, representing leakage reactance of generator, and parallel capacitor, representing line capacitance, on generator side of switch.

Recovery voltage transients:

Typical voltage transient amplitude of $2V_m$ and natural frequency of $1/(LC)^{1/2}$.

Derivation of expression for RRRV (rate of rise of recovery voltage).

Typical arc behaviour:

typical oscillogram showing system voltage, fault current, arc voltage, recovery voltage transient, recovery voltage.

Principles of arc suppression and control:

types of contact breaker, high voltage fuses; device ratings and application.

Outcome 8:

Overcurrent protection - the distinction between a.c. and d.c. parts of the system.

a.c. main elements:

current transformers, voltage transformers; summation transformers; relays.

IDMT overcurrent relay (Inverse Definite Minimum Time):

time settings, current settings. Plug setting multiplier. Time grading of relays.

Unit protection systems:

circulating current differential protection used to protect three-phase generators and transformers. Volt-drop diagrams.

Overvoltage protection:

causes including lightning, switching, fault clearance; preventive methods including overhead earth wire, horn-gap, surge diverter.

PC (d) Other possible unit protection schemes include simple balanced voltage protection and use of summation transformer to reduce number of pilot wires.

Outcome 9:

Economics of supply:

capital costs, variable costs, load and demand.

Matching supply and demand:

load curves; spinning and static reserves.

Industrial tariffs:

two-part tariffs;
demand monitoring;
Application of tariffs, calculations.

PC (a) Capital costs are also called fixed costs or standing charges. They include: salaries; maintenance; administration; marketing; design and development.

Interest and depreciation have been itemised separately but could be included in capital costs.

Diversity factor = (sum of all possible demands)/(actual demand)

Load factor = (energy consumed)/(energy consumed if maximum load was maintained)

Assessment of PC(c) requires only a simple two-part tariff. Current tariff sheets can be obtained from the local supply authority.

ASSESSMENT PROCEDURES

Centres can use the Instruments of Assessment that they consider to be most appropriate.

EXEMPLARS

Outcome 1

PC (d)

Explain:

- a) why discrimination is necessary on an electrical supply system;
- b) which relay on the radial feeder shown below will have the shortest operating time when a short circuit occurs between sections C and D.



PC (c)

Determine the load voltage levels of each of the distribution feeder systems shown below:

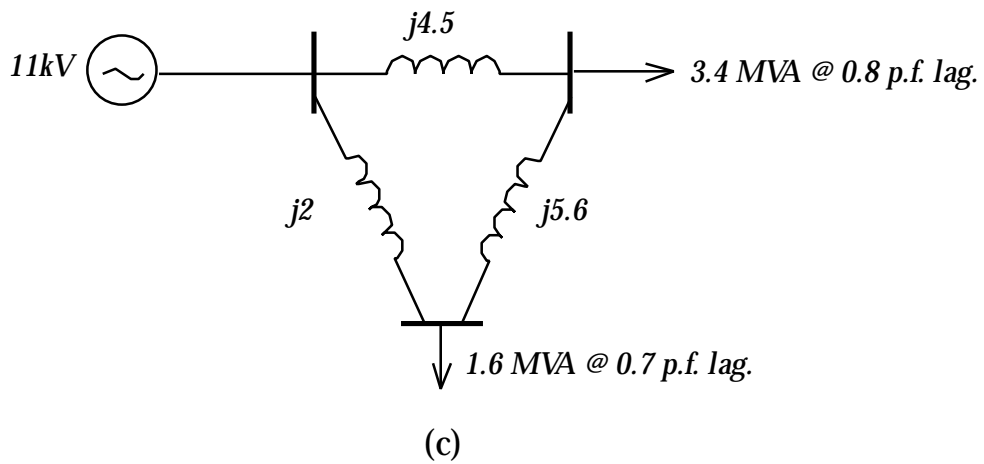
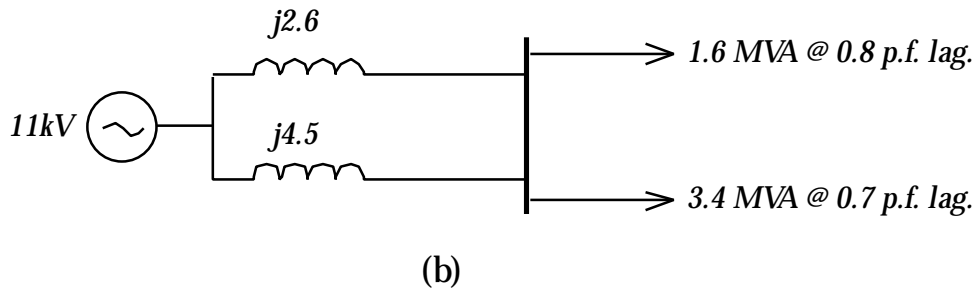
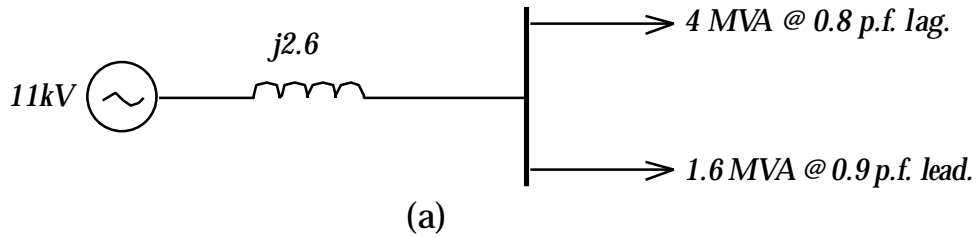
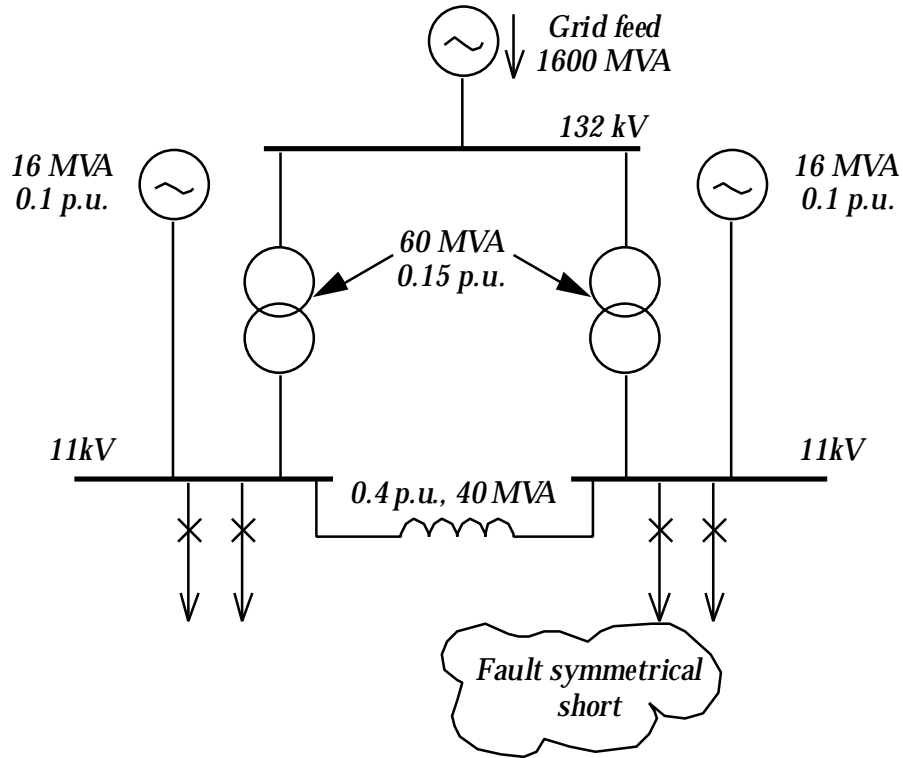

Fig 1

Outcome 3

PC (a)

For the arrangement shown in the diagram below calculate the fault level for a three-phase symmetrical short circuit on an 11 kV feeder. (Use a 40 MVA base.)

**Fig 2**

Outcome 4

PC (a) & (b)

An 11 kV line of series impedance $(5.3 + j7.9)$ ohms per phase delivers a load of 5.6 MW at a power factor of 0.84 lagging.

- (a) Calculate the sending-end voltage and load angle.
- (b) Construct the receiving-end performance chart for the line and load.
- (c) Determine the real and reactive power when the sending-end voltage is increased by 30% but the transmission angle remains the same.
- (d) Determine the real and reactive power when the sending-end voltage is decreased by 15% and the transmission angle is increased by 9° .

Outcome 5

PC (a)

The data below pertains to a 600 MVA three-phase synchronous generator that is assumed to be working to an infinite busbar. Construct the machine's capability chart.

| | |
|-----------------------|-------------------------|
| Excitation limit | 3 p.u. |
| Synchronous reactance | 2.2 p.u. |
| Stability margin | 15% of full load power. |
| Turbine power limit | 550 MVA |
| Maximum margin | 600 MVA |

Outcome 6

PC (c)

Two transformers are connected in parallel to supply a common load. One is rated at 500 kVA with an impedance of $(0.1 + j0.13)$ and the other at 300 kVA with an impedance of $(0.07 + j0.1)$. Determine the percentage overload of the smaller transformer when the larger one supplies its full load.

Outcome 7

PC (c)

A 11kV contact breaker can be represented, for switching transient purposes, by a set of contacts with a 15mH series inductor and a 0.17 μ F shunt capacitor. If the CB clears a short circuit fault calculate:

- (a) the frequency of the recovery voltage transient;
- (b) the maximum voltage across the CB;
- (c) the RRRV.

Outcome 8

PC (c)

A 33 kV three-phase system is protected using 1000/5 CTs and IDMT relays with a plug setting of 200% and time multipliers of 0.32. If the system is subject to a 200 MVA line-to-line short circuit calculate the time from the onset of the fault to initiation of the CB trip.

Outcome 9

PC (c)

The meter readings for one month for a small industrial unit that takes its supply at low voltage are given below. Determine the average power factor and the bill for the month, including vat.

| | | | | |
|-------|-----|-------|-------|------|
| kWhr | day | 40256 | night | 7621 |
| kvarh | day | 10126 | night | 2785 |
| MD | day | 321 | night | 56 |

REFERENCES

1. Guide to unit writing, SQA, 1993 (Code A018).
2. Guide to assessment, SQA, 1993 (Code B005).
3. Guide to certification, SQA, 1993 (Code B005).
4. Notes for unit writers, SQA, 1995 (Code A041).

For details of other SQA publications, please contact staff at the Administrative Services Unit (Tel: 0141-242 2168) who can supply you with a copy of the publications list (Code: X037).

© Copyright SQA 1998

Please note that this publication may be reproduced in whole or in part for educational purposes provided that:

- (i) no profit is derived from the reproduction;
- (ii) if reproduced in part, the source is acknowledged.